

9. Recorder Settings

Ensure the recorder channel connected to the HD3S Stop Arm Camera has Camera Settings as follows (for detailed instructions, see the recorder documentation).

1. Right-click in the camera live view to access recorder menus.
2. Go to **Configuration > Record > Camera**.
3. If your recorder displays multiple Camera Settings tabs (Summary, Analog, IPC, RTSP), click the **Analog** tab.
4. Set the following values:
FPS to 15 fps, **Quality** to 4, and **Resolution** to 1920 X 1080



Specifications

Power Consumption	5.2 W max. @ 12 VDC
Operating Voltage Range	9 to 14 VDC (powered by DVR)
Operating Temperature Range	-40 to 122°F (-40 to 50°C)
Horizontal Resolution	1080p
Infrared LED Lamps	4 high efficiency LEDs
Minimum Illumination	0.7 lx at F2.0, 0 lx (IR on)
Enclosure Size, LxWxH	5.16" (131 mm) x 3.45" (88 mm) x 3" (77 mm)
Enclosure Material	Solid aluminum alloy, powder-coated
Window	Impact-resistant polycarbonate, scratch-resistant, UV protected
Connector Cable length	9.5" (24.1 cm)
Weight	1.22 lbs (554 g)

Routine Maintenance

Most liquid cleaners or graffiti gel can be used to clean your camera enclosure. Do not use abrasive cleaners that can scratch the window and reduce visibility of the camera.

Replacing a Damaged Camera or Camera Top Lid Assembly*

If the camera window is damaged or scratched, a replacement Top Lid Assembly (PN 050-1019) can be ordered from your distributor. For any other inquiries to address camera damage, contact the Safe Fleet Technical Support Team.

*The Top Lid Assembly includes IR LEDs. The lid is connected to the camera base by both a cable for the LEDs and a short lanyard to prevent excessive stress on the cable. Contact Safe Fleet Support for instructions on how to disconnect and reinstall the cable and lanyard.

Service

If your HD3S Stop Arm Camera is to be returned for service, please contact the Safe Fleet technical support team, provide the model and/or serial# of your unit, and ask for a **Return Merchandise Authorization (RMA)** number. An **RMA#** allows the support team to better track your product when it comes in for service. Please show the RMA# on the **outside** of the package.

ANY PRODUCT SENT WITHOUT AN RMA# MAY BE REFUSED!

Technical Support

- Email: PTsupport@safefleet.net
- Phone: 1.844.899.7366

Documentation

Additional copies of this guide, along with other supporting documentation can be found on the SafeFleet Community (<https://community.safefleet.net>)

HD3S Stop Arm Camera Quick Installation Guide

Installation Kit Contents

- 1x HD3S wedge camera
- 1x security key
- 3x #10 3/4" Phillips screws
- 1x Drilling template

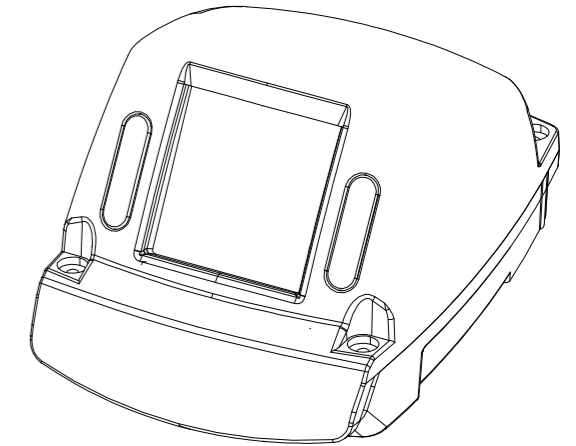

CAUTION: Cable Compatibility

This camera requires a special Analog High Definition (AHD) cable - as indicated by a blue band in front of the connectors. A standard cable may appear to work on a small analog screen, but the image will be significantly degraded during subsequent playback.

1. Choose Camera Location

1. Select a flat location to minimize possible moisture leakage into the vehicle. Cameras must be installed with the cabling running inside the wall panels.
2. Use the supplied drilling guide template to mark the cable (7/8") and screw (5/32") holes on the panel.
3. Use a step-bit to drill the cable hole, and regular bits for the screw holes.

TIP: Seal the Camera Mounting Holes

For outdoor installations, if a flat surface is not available, carefully seal the mounting holes under the base of the camera after installation. Do NOT apply silicone or other sealants around the base of the camera.

2. Connect the Camera

1. Connect the camera cable to the extension cable through the panel cable hole. See Figure 1. Ensure the extension cable has a blue band in front of the connectors, indicating it is AHD (Analog High Definition)-compatible.
2. Connect the extension cable's 2x3 Micro-Fit connector into a digital video recorder (DVR).

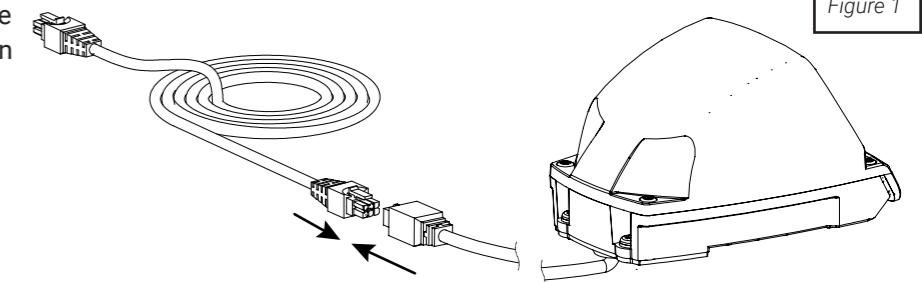

3. Open the Camera

1. Using the security key supplied with the camera, loosen the four captive screws on the housing. See Figure 2.
2. Lift the housing off of the base.

TIP: Housing Can Scratch Vehicle

When the camera cover is open, take care to ensure it does not flop against the vehicle surface. Damage to paint can occur.

- 1: Top lid assembly
- 2: Captive housing screws
- 3: IR LED/ground wires and lanyard
- 4: Menu button
- 5: Camera gimbal
- 6: Local video out
- 7: Base
- 8: Camera sealing gasket

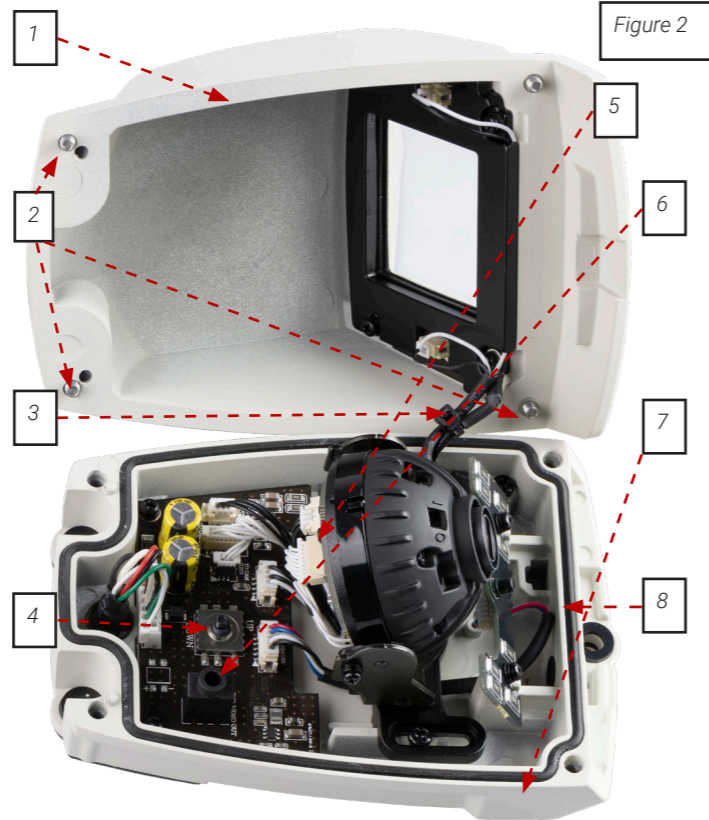

CAUTION: Camera and PCB Wiring

While installing the camera, do not impact the printed circuit board or wiring inside the camera with screws or screwdriver bits. Damage to the camera can occur.

4. Install the Camera

TIP: Allow Camera Ventilation

The camera is designed to vent for proper operation. Do NOT apply silicone or other sealants around the base of the camera.

Use the three #10x3/4" mounting screws supplied with the camera to attach the camera to a wall or ceiling. See Figure 3.

The mounting gaskets on the camera base seal the screw and cable holes when mounted on a flat surface.

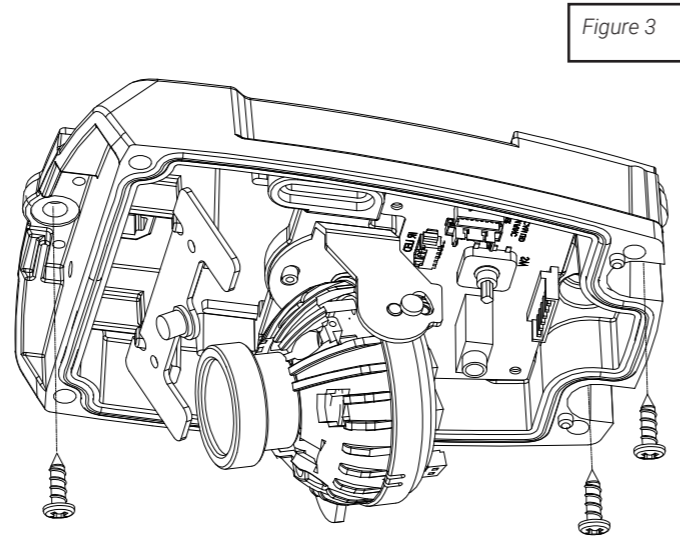

5. View Camera Output

1. Power on the DVR and camera.
2. Connect the supplied local video out adapter cable's 3.5mm audio plug to the camera's Local Video Out socket. See figure 2.
3. Connect the local video out cable's RCA end to a video monitor to see the camera's line of view while adjusting the camera's rotation, pan, and tilt positions.

6. Aim the Camera

To get the required video image, adjust the camera's rotation, pan, and tilt settings using the adjustment controls shown in Figure 4 and described in the following steps:

1. **Rotation:** depending on how the camera is mounted, rotate the camera lens so the video appears upright on the video monitor.
2. **Pan:** grip the camera pan adjustment U-Bracket sides and twist it to find the required view.
3. **Tilt:** loosen the tilt adjustment screws on the U-Bracket until the camera tilts. Tighten the tilt screws after adjustments are complete. Do not adjust tilt after tightening screws.

TIP: Do Not Adjust Other Screws

The HD3S camera is factory adjusted for lens position. Sliding back the gimbal may result in the camera seeing parts of the housing.

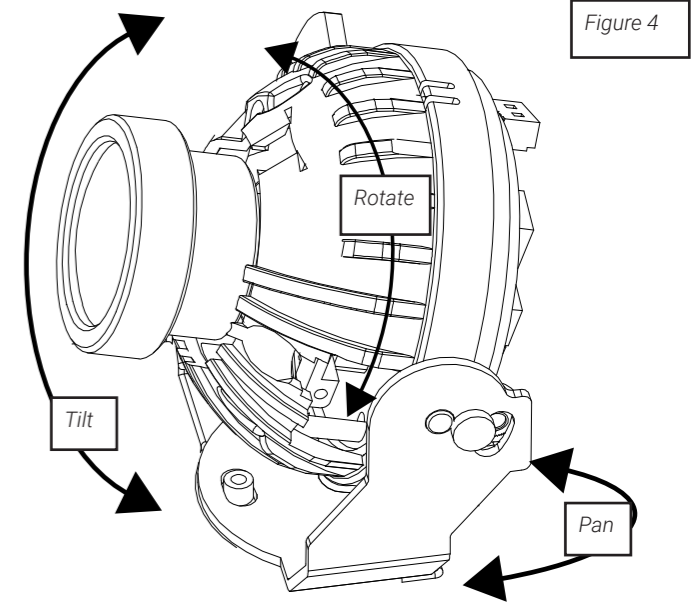

TIP: Check Video Output from DVR

After replacing camera housing, ensure the desired field of view is achieved. Adjust if camera housing obstructs the view.

7. Configuration Settings

* Camera configuration settings are also accessible from your recorder via CoC (Control over Coax) on-screen display menus. For more information, consult your recorder documentation.

1. In the camera, press the menu button to display the configuration menu on the monitor.
2. Toggle the button up or down to select from BACKLIGHT or EXT LED options, or to SAVE and EXIT.
3. With an option selected, toggle the button left or right to select sub menu options.
4. Toggle up or down to exit the option and select SAVE and EXIT.

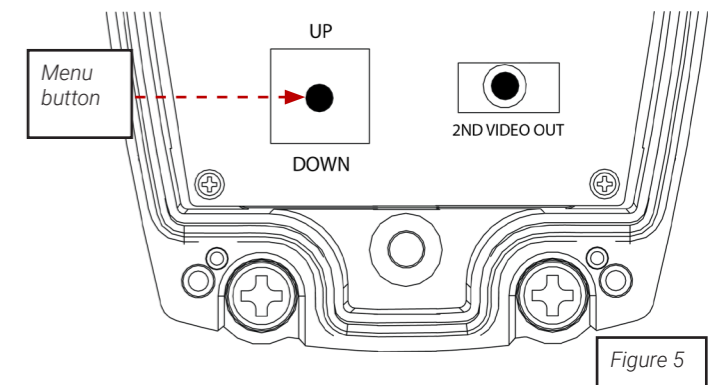

BLC (Back Light Compensation)	OFF: (default) shutter speed is based on the light level of the entire image.
WDR (Wide Dynamic Range)	BLC: helps improve image quality when back lighting is strong. WDR: helps reduce glare for scenes with simultaneous wide variance in lighting.
External LED	OFF: IR is disabled. Use in product configurations where IR is not required. AUTO: (default) IR LEDs illuminate automatically upon HD3S sensing a low light condition.

8. Replace Camera Housing

1. Close the housing back over onto the base.
2. Use the security key to tighten the four captive locking screws. See 3, 7, and 8 in figure 2.

CAUTION: Do Not Pinch Safety Wire

Ensure closing the cover does not pinch the wire connecting the cover to the base. This can allow moisture to enter and damage the unit.