

## 8. Replace Camera Housing

1. Close the housing back over onto the base.
2. Use the security key to tighten the four captive locking screws. See Figure 2.

### CAUTION: Do Not Pinch Safety Wire

Ensure closing the cover does not pinch the wire connecting the cover to the base. This can allow moisture to enter and damage the unit.

## Specifications

Power Consumption	7 W max. @ 12 VDC
Operating Voltage Range	9 to 14 VDC (powered by DVR)
Operating Temperature Range	-40 to 140°F (-40 to 60°C)
Horizontal Resolution	700 TV Lines
Infrared LED Lamps	4 high efficiency LEDs
Minimum Illumination	0.061 lux at F2.0 0 lux (IR on)
Enclosure Size, LxWxH	5.16" (131 mm) x 3.45 " (88 mm) x 3" (77 mm)
Enclosure Material	Solid aluminum alloy, powder-coated
Window	Impact-resistant polycarbonate, scratch-resistant, UV protected
Connector Cable length	9.5" (24.1 cm)
Weight	1.22 lbs (554 g)

### Routine Maintenance

Most liquid cleaners or graffiti gel can be used to clean your camera enclosure. Do not use abrasive cleaners that can scratch the window and reduce visibility of the camera.

### Replacing a Damaged Camera

If the camera window is damaged or scratched, order a replacement camera from your distributor. To remove and replace the housing, follow the steps in section 3 **Open the Camera** and section 8 **Replace Camera Housing**.

For any other inquiries to address camera damage, contact the Safe Fleet Technical Support Team..

## Warranty

For full warranty information, go to <https://www.safefleet.net/documents/Seon-Warranty.pdf>

## Service

If your CA10 Wedge Camera is to be returned for service, please contact the Safe Fleet technical support team, provide the model and/ or serial# of your unit, and ask for a **Return Merchandise Authorization (RMA)** number. An **RMA#** allows the support team to better track your product when it comes in for service. Please show the RMA# on the **outside** of the package.

ANY PRODUCT SENT WITHOUT AN RMA# MAY BE REFUSED!

## Technical Support

- Email: [PTsupport@safefleet.net](mailto:PTsupport@safefleet.net)
- Phone: 1.844.899.7366

## Documentation

Additional copies of this guide, along with other supporting documentation can be found on the SafeFleet Community (<https://community.safefleet.net>)

Information in this guide is subject to change without notice.



# Wedge Camera CA10

## Quick Installation Guide

## Installation Kit Contents

- 1x CA Series wedge camera
- 1x security key
- 3x #10 3/4" Phillips screws
- 1x Drilling template

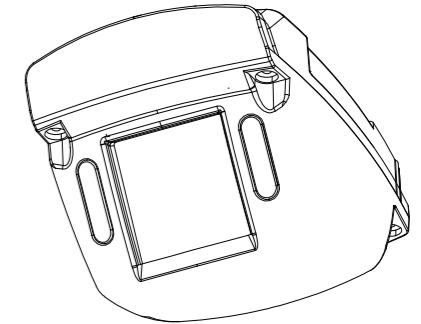

## 1. Choose Camera Location

1. Select a flat location to minimize possible moisture leakage into the vehicle. Cameras must be installed with the cabling running inside the wall panels.
2. Use the supplied drilling guide template to mark the cable (7/8") and screw (5/32") holes on the panel.
3. Use a step-bit to drill the cable hole, and regular bits for the screw holes.

### TIP: Seal the Camera Mounting Holes

For outdoor installations, if a flat surface is not available, carefully seal the mounting holes under the base of the camera after installation. Do NOT apply silicone or other sealants around the base of the camera.

## 2. Connect the Camera

1. Connect the camera cable to the extension cable through the panel cable hole. See Figure 1.
2. Connect the extension cable's 2x3 Micro-Fit connector into a Digital Video Recorder (DVR).

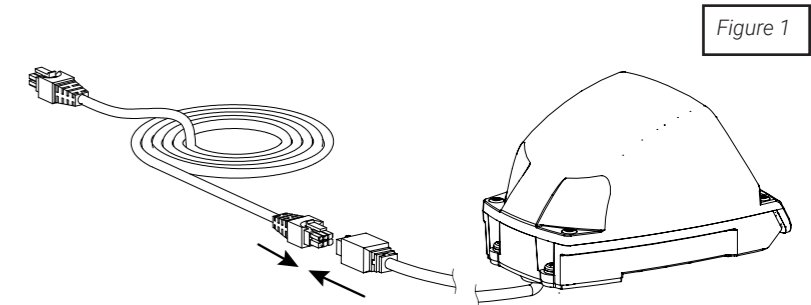

## 3. Open the Camera

1. Using the security key supplied with the camera, loosen the four captive screws on the housing. See Figure 2.
2. Lift the housing off of the base.

### TIP: Cover and base are connected

Do not strain the LED and ground wires connecting the cover to the base. Damage to the camera can occur.

When the camera cover is open, take care to ensure it does not flop against the vehicle surface. Damage to paint can occur.

### 3. Open the Camera *(continued)*

- 1: Top lid assembly
- 2: Captive housing screws
- 3: LED and ground connection wires
- 4: Menu button
- 5: Camera gimbal
- 6: Local video out
- 7: Camera sealing gasket
- 8: Base

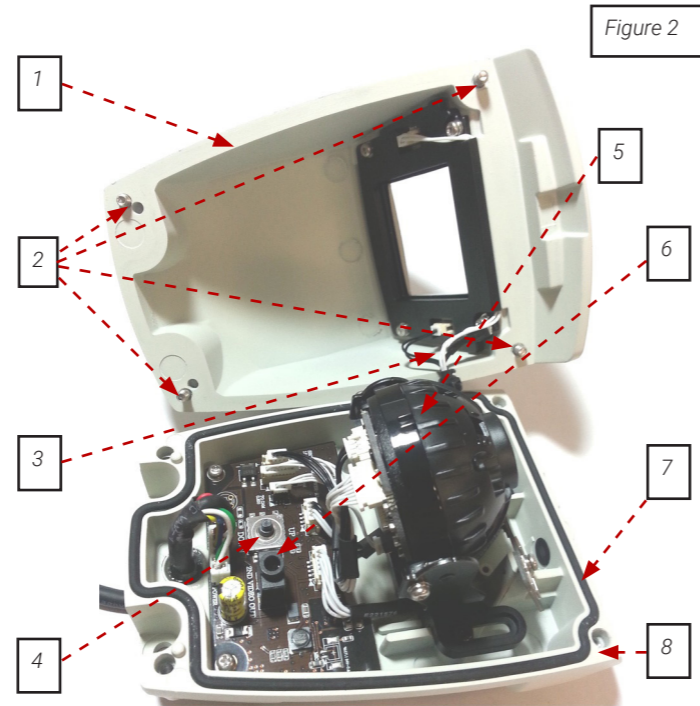

#### CAUTION: Camera PCB and Wiring

While installing the camera, do not impact the printed circuit board or wiring inside the camera with screws or screwdriver bits. Damage to the camera can occur.

### 4. Install the Camera

#### TIP: Allow Camera Ventilation

The camera is designed to vent for proper operation. **Do NOT** apply silicone or other sealants around the base of the camera.

Use the three #10×3/4" mounting screws supplied with the camera to attach the camera to a wall or ceiling. See Figure 3.

The mounting gaskets on the camera base seal the screw and cable holes when mounted on a flat surface.

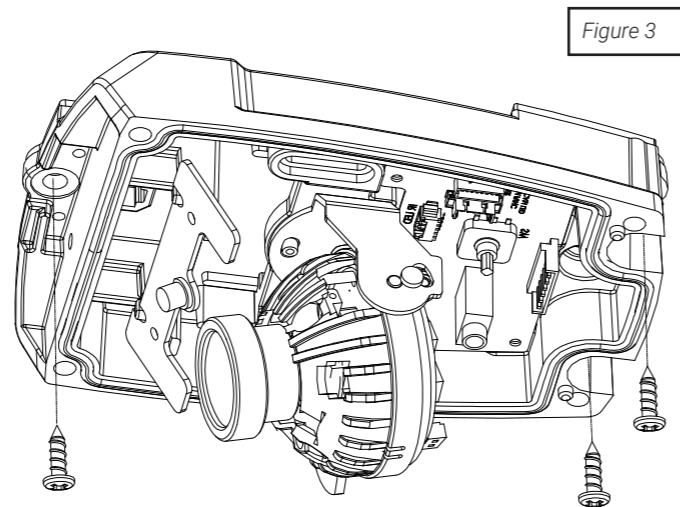

### 5. View Camera Output

1. Power on the DVR and camera.
2. Connect the supplied local video out adapter cable's 3.5mm audio plug to the camera's Local Video Out socket. See Figure 2.
3. Connect the local video out cable's RCA end to a video monitor to see the camera's line of view while adjusting the camera's rotation, pan, and tilt positions.

### 6. Aim the Camera

To get the required video image, adjust the camera's rotation, pan, and tilt settings using the adjustment controls shown in Figure 4 and described in the following steps:

1. **Rotation and Tilt:**
  - i. Loosen both tilt adjustment screws on the U-Bracket until the camera rotates/tilts.
  - ii. Depending on how the camera is mounted, rotate and/or tilt the camera lens so video appears upright on the video monitor.
  - iii. Tighten the tilt screws after adjustments are complete. **Do not adjust rotate/tilt after tightening screws.**
2. **Pan:** grip the camera pan adjustment U-Bracket sides and twist it to find the required view.

#### TIP: Do Not Adjust Other Screws

The CA10 camera is factory adjusted for lens position. Sliding back the gimbal may result in the camera seeing parts of the housing.

#### IMPORTANT: Tilt Adjustment Screws

Do not attempt to adjust gimbal rotation or tilt before loosening the adjustment screws on the U-bracket.

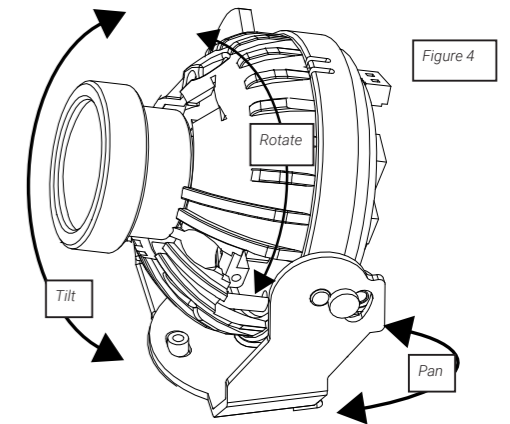

#### TIP: Check Video Output from DVR

After replacing camera housing, ensure the desired field of view is achieved. Adjust if camera housing obstructs the view.

### 7. Configuration Settings

1. In the camera, press the menu button to display the configuration menu on the monitor.
2. Toggle the button up or down to select from BACKLIGHT or EXT LED options, or to SAVE and EXIT.
3. With an option selected, toggle the button left or right to select submenu options.
4. Toggle up or down to exit the option and select SAVE and EXIT.

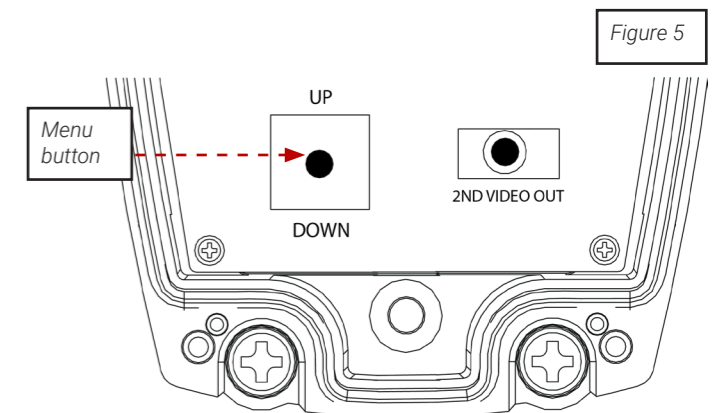

<b>BLC (Back Light Compensation)</b>	OFF: (default) shutter speed is based on the light level of the entire image.
<b>WDR (Wide Dynamic Range)</b>	BLC: helps improve image quality when back lighting is strong. WDR: helps reduce glare for scenes with simultaneous wide variance in lighting.
<b>External LED</b>	OFF: IR is disabled. Use in product configurations where IR is not required. AUTO: (default) IR LEDs illuminate automatically upon CA10 sensing a low light condition.

Fold Here