

Accessing the Camera Using a Web Browser

You can use a Web browser to access and configure the camera over an Ethernet connection. For a direct connection to a single camera:

1. Using a Web browser, enter the camera's IP address (*refer to the table below*). The Login dialog box appears.
2. Enter your user name and password. Default user name is **Admin** and default password is **11111111**.
3. Click **LOGIN**. The Web browser **Live View** appears.

NOTE: Browser Requirements

Chrome, Firefox, and Microsoft Edge are supported.

Internet Explorer is not supported.



C5W1PD

Quick Install Guide

For camera models:

C5W1PD104E, C5W1PD104E-G, C5W1PD078E, C5W1PD078E-G
C5W1PD104E-SD128, C5W1PD104E-G-SD128,
C5W1PD078E-SD128, C5W1PD078E-G-SD128

Typical IP Addresses

The camera's default static IP address is 172.30.1.1. When connected to the network switch or directly to a recorder, the camera's IP address is assigned based on the device and port:

Connected Device	IP Address Range	Port Name	IP Address	
16-port Network switch (NS18POE16)	172.31.1.101 through 172.31.1.116	<P01-P16>	Change the last 2 digits based the port number. For example: the address for the camera connected to switch port #8 is: 172.31.1.108	
NH16 & NH16v2 recorders (directly to rear-panel)	172.31.1.141 through 172.31.1.144	NH16	NH16v2	Both Models
		IPCAM1	POE01	172.31.1.141
		IPCAM 2	POE02G	172.31.1.142
		WIFI	POE03	172.31.1.143
TH8 recorder (directly to rear panel)	172.31.1.141 and 172.31.1.142	Modem	POE04	172.31.1.144
		HD Cam Expansion 1		172.31.1.141
DH4v2, DH6 & DH8 recorders (directly to rear panel)	N/A	HD Cam Expansion 2		172.31.1.142
		LAN2		172.31.1.141

Documentation

Additional copies of this guide, along with other supporting documentation can be found on the Safe Fleet Community: <https://community.safefleet.net>

Information is subject to change without notice. For the latest version, please check Safe Fleet Community

Warranty

For full warranty information, visit:

<https://www.safefleet.net/documents/Seon-Warranty.pdf>

Support

- Phone: 1.844.899.7366
- Email: PTsupport@safefleet.net

Package Contents

Check the package and contents for visible damage. If any components are damaged or missing, contact the Safe Fleet Service team and request an RMA (Return Material Authorization).

Package contents:

- Camera
- Drill Template (part # 700-1327)
- Torx Security Wrench (part # 645-1019)
- Weatherproof cap for RJ45 connector (part # C5CAP)
- Qty 4 - #10, 1" Mounting Screws (part # 600-1083)

Cable Requirements

It is recommended that camera harnesses be purchased directly from Safe Fleet. All network cabling must be installed according to applicable codes and regulations.

Cable should be CAT5e or CAT6, stranded or solid, 24 AWG or better. Both ends of the camera harness must be terminated with male RJ45 connectors and conform to the same wiring standard (T568A or B). Spliced cables are not acceptable.

Service

If your C5W1PD Camera is to be returned for service, please call toll free 1.877.630.7366, or 1.844.899.7366, and provide the model and/or serial# of your unit.

Ask for a Return Merchandise Authorization (RMA) number. An RMA# allows the Service Technicians to better track your product when it comes in for service. Please show the RMA# on the outside of the package. ANY PRODUCT SENT WITHOUT AN RMA# MAY BE REFUSED.

Camera Components

1. Cover[#]
2. Bubble
3. LED Windows
4. Base
5. Lens
6. Camera Sealing Gasket
7. LAN/PoE RJ45 Cable
8. 12V Power Input^{*}
9. BNC Connection
10. Micro SD Card Slot
11. Reset Button[†]

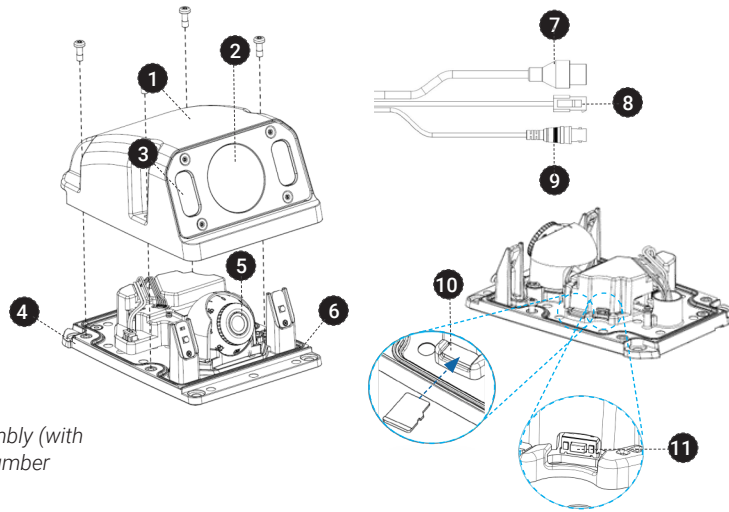

[#] Replacement camera lid assembly (with polycarbonate bubble) is part number C5W1PD-TOP-LID-PC.

^{*} Connection not necessary when PoE is used. Expected to be utilized for legacy applications whereby only the SDA video output is used through the BNC connector. Only use a power supply from the recorder - 12VDC (9.0V ~ 15.0V).

[†] To restore all camera settings (including network settings) to factory defaults, press and hold the Reset Button for up to 10 seconds (camera will reboot).

Mounting the Camera

1. Use the supplied template to mark out the mounting area. Drill the screw holes and cable hole on the surface.
2. Pull the camera harness through the cable hole.
3. Loosen the cover screws to remove the cover from the camera and fix the mounting base to the surface with the appropriate screws.
4. Loosen the Phillips screws on each side of the gimbal to adjust the pan, tilt, and rotation angle, then re-tighten the screws.

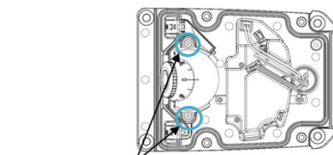
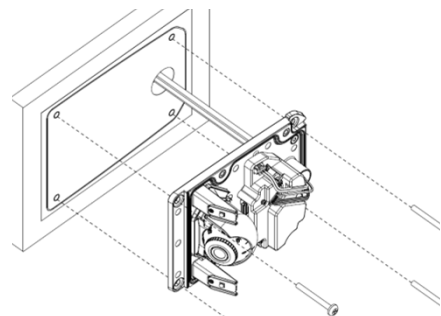

Phillips Screws

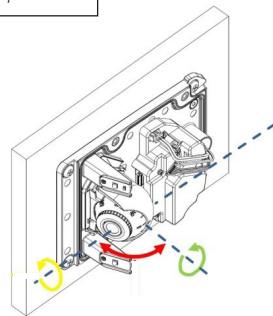

5. Finally, re-install the cover using the cover screws.
 - Torque the cover-to-base captive screws to 15 kgf-cm (13 in-lb).

Improper mounting can potentially result in water damage to the camera. Please see the note and warning on the next page of this Guide.

Important: Positioning the Lens - Image Orientation

Check the camera image in a monitor and fine-tune the gimbal position accordingly to achieve the desired view. **The "180" mark on the gimbal housing indicates the top of the rendered image.**

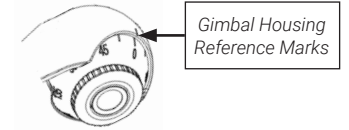

Gimbal Housing Reference Marks

For reverse/backup installations, we recommend using the image rotation function available via the camera's Web client to **rotate the camera image 180 degrees**:

1. Follow the steps in "Accessing the Camera Using a Web Browser" on the next page.
2. From **Live View**, use the left-hand navigation bar to select **Image** → **Image Configs**.
3. Under **Rotate View**, use the **Video Orientation** menu to select **180°**.
4. Select **Save All**.



Important: Camera Sealing

Keep the camera sealing gasket clear of any debris and/or cables prior to installing the lid to ensure a reliable seal. Also, take care not to damage the gasket during installation.

Do not use sealant or silicone at the camera base or along the seam between the lid and base.

Note: The camera is designed with a breather vent located at the rear of the base, which is covered by protective film during shipping; peel off the film when unpacking the camera, and ensure the vent is not blocked after installation

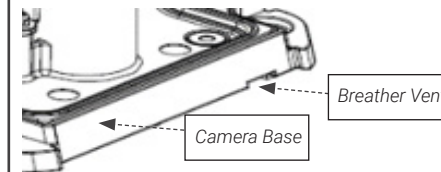

Breather Vent

Camera Base

Do not allow paint inside the gasket cavity or the camera housing – mask off the gasket cavity and all inside parts if painting the lid and base separately.

WARNING: Ensure mounting screws do not impede the camera cover

The gasket running along the mounting base prevents water from seeping inside the camera, which may damage internal components. To ensure a tight seal and avoid compromising the gasket, install the mounting screws in accordance with the following conditions:

- **Oversized screw heads** – we recommend using the supplied mounting screws. While this suits most installations, different-sized screws may be required for specific vehicles. If you use a different-sized screw, ensure it does not impede the camera cover from fully sealing.
- **Drilling/screw angle** – when fully-inserted, the screw heads must sit flush with the countersunk holes in the mounting base. Do not drill/thread the mounting screws at an angle or off-center, as this can pinch or obstruct the base plate gasket.

Fold Here